

Cargo Aids

- Many of our products have been developed through requests by customers. When a device was required to tie down the EH101 Merlin Helicopter securely to the deck of a ship, Agusta Westland turned to Cargo Aids and the MC2 Storm Lashing was developed.
- The polyester webbing tie-down has a fast single action, over centre mechanism that gives tension and locking in one movement.
- Quick release is also achieved in one easy action. The MC2 Storm Lashing has a unique clutch that means that slack can be taken up without reloading the mechanism.
- The webbing is treated to resist abrasion and the effects of sunlight. The mechanical components are of replaceable corrosion resistant steel selected to give maximum durability.
- The unit incorporates a web tidy to ensure compact and safe stowage of excess webbing and its unique mechanism is a patented design. Recent modifications have removed any potential FOD hazards.

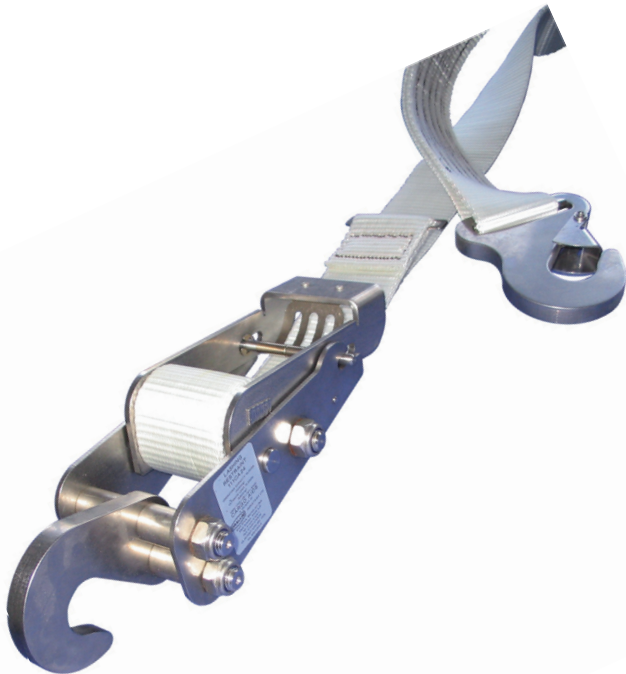

As used by the Royal Navy

Having successfully undergone sea trials the MC2 Storm Lashing is now in use throughout the Royal Navy. The need for heavy and noisy chain-based restraints is no longer necessary.

15,000lb Ultimate Load

The MC2 Storm Lashing is designed for loads of up to 10,000lb (4536 Kg) and is capable of an ultimate load of 15,000lb (6804 kg).

Easy Load Quick Release

The MC2 Storm Lashing features a fast single action over centre mechanism that gives tension and locking in one easy movement.

Specification

■ Part Number:	111CA24
■ Design Load:	10,000 lb (4536 kg)
■ Ultimate Load:	15,000 lb (6804 kg)
■ Weight with 6 mtr Webbing:	9 lb (4.1 kg)
■ Webbing width:	60 mm
■ Nato Stock Number (NSN):	1730-99-1518223
■ Material:	Stainless Steel

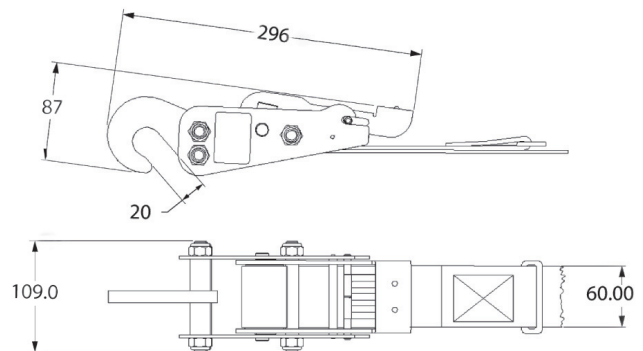

MC2 Storm Lashing

The Drallim Group

Leading innovators in technology and quality