

HYDROCAL 1005 Offshore

Multi-Gas-in-Oil Analysis System with Transformer Monitoring Functions for Offshore Applications



The HYDROCAL 1005 is a permanently installed multi-gas-in-oil analysis system with transformer monitoring functions. It individually measures, Moisture in oil (H_2O) and the key gases Hydrogen (H_2), Carbon Monoxide (CO), Acetylene (C_2H_2) and Ethylene (C_2H_4) dissolved in transformer oil.

As Hydrogen (H_2) is involved in nearly every fault of the isolation system of power transformers and Carbon Monoxide (CO) is a sign of an involvement of the cellulose / paper isolation, the presence and increase of Acetylene (C_2H_2) and Ethylene (C_2H_4) further classifies the nature of a fault as overheating, partial discharge or high energy arcing.

As an option / special version of the HYDROCAL 1005, the HYDROCAL 1005 *Offshore* is specially designed for the harsh conditions (salt water, corrosion) on offshore platforms (e.g. offshore wind mill parks). A special painted housing with no window and the application of chrome nickel and stainless steel ensures the reliability and the persistence of the device.

The device can serve as a compact transformer monitoring system by the integration / connection of other sensors present on a transformer via its optional analog inputs:

- 4 analog inputs 0/4 ... 20 mA DC
- 6 analog inputs 0/4 ... 20 mA AC +20% or 0 ... 80 VAC +20% (configurable by jumpers)

It is further equipped with digital outputs for the transmission of alerts or the execution of control functions (e.g. control of a cooling system of a transformer):

- 5 digital relay outputs
- 5 digital optocoupler outputs (option)

Key Advantages

- Individual measurement of Hydrogen (H_2), Carbon Monoxide (CO), Acetylene (C_2H_2) and Ethylene (C_2H_4)
- Moisture in oil (H_2O) measurement
- Special design for offshore applications:
 - Housing without window painted in C5M
 - Back plate with 2 cable glands M20 (chrome-nickel steel, IP 68, corrosion-free and acid-resistant)
 - Back plate, oil entrance and housing screws made of stainless steel V4A
- Maintenance free system
- Easy to mount on a transformer valve (G 1 1/2" DIN ISO 228-1 or 1 1/2" NPT ANSI B 1.20.1)
- Installation on the operating transformer without any operational interruption
- Communication interfaces ETHERNET 10/100 Mbit/s (copper-wired / RJ 45 or fibre-optical / SC Duplex) and RS 485 to support MODBUS[®] RTU/ASCII, MODBUS[®] TCP, DNP3 and proprietary communication protocols and to be open / prepared for substation communication protocol IEC 61850
- Optional on-board GSM or analog modem for remote access
- Optional DNP3 serial modem for SCADA connection
- Optional HV and LV bushing sensors for HV and LV bushing monitoring applications via communication interface

Transformer monitoring functions

Voltagages and currents

(via voltage and current transformers / transducer)

Temperature Monitoring

Bottom and top oil temperature, ambient temperature
(via additional temperature sensors)

Cooling Stage / Tap Changer Position

(e.g. via current transducer)

Free configuration

Analog inputs can be free allocated to any additional sensor

Further calculations:

Hot-Spot (acc. IEC 60076) } joint development
Loss-of-Life } with PAUWELS
Ageing Rate } Belgium

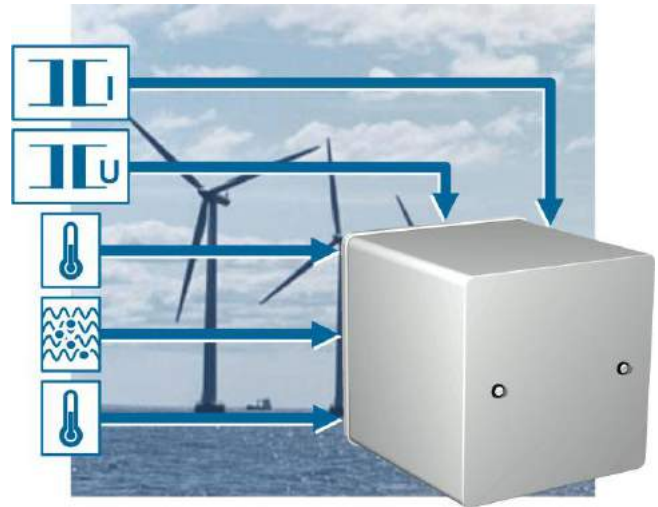

HV and LV Bushing monitoring functions (option)

The Bushing Monitoring system simultaneously monitors the bushing leakage current of two rows of three phase groups of bushings. The system incorporates three different measurement modes on each tested component to provide accurate power factor and capacitance values to evaluate the condition of bushing insulation. The measurement modes are the following:

Phase comparison

Compares the power factor of tested components with other tested components energized with the same phase voltage.

Sum of three current tests

Measures the imbalance current from the summation of A, B and C phase currents from three tested components such as the three HV or LV bushings on the transformer.

Adjacent phase reference test

compares the power factor of the tested components with other phase components on the same equipment.

The bushing sensors / adapters are connected to the capacitor taps designed for all types of bushings to allow measurement of the leakage current up to 140 mA. The adapters are designed for bushings with grounded and underground capacitor taps. The adapter is designed to prevent a voltage developing on the equipment, in case the sensor is disconnected from the Bushing Monitoring system.

Different bushing sensor configurations are possible:

- Monitoring of high-voltage side
- Monitoring of high- and low-voltage side
- Reference HV bushing from other transformers
- Reference CCVT / CCPT

Configuration with 3, 6, 9¹⁾ or 12¹⁾ bushing sensors are possible.

Notes

¹⁾ Two bushing monitoring units necessary

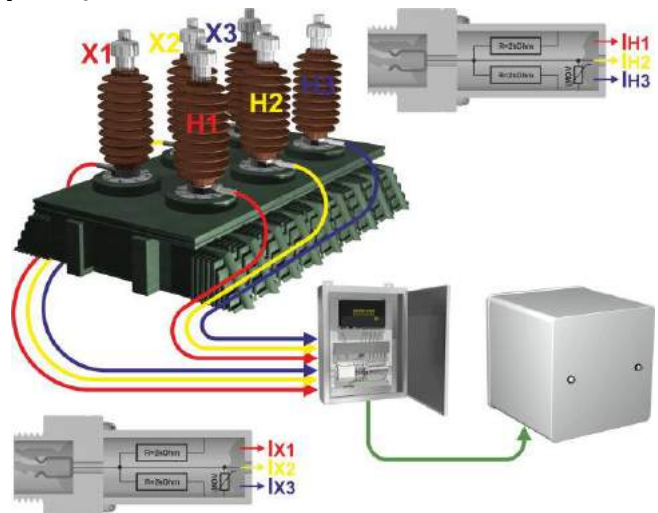

Monitoring of high- and low-voltage side

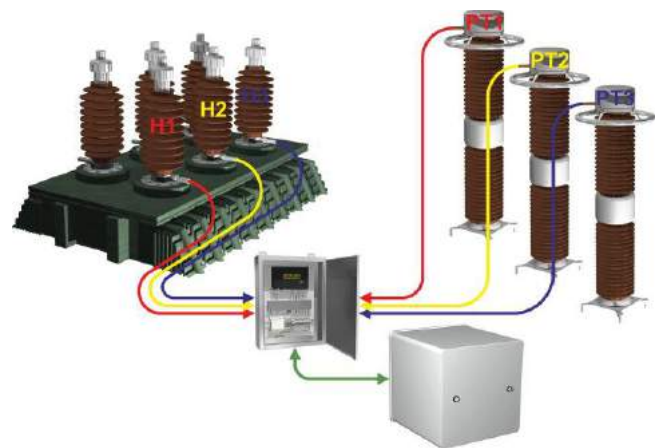

Reference CCVT / CCPT

HYDROCAL firmware main menu

1 Extraction status

- Shows the actual operating status of the unit

2 Gas-in-oil overview

- Column chart
- Trend graph
- Data table

3 Transformer specific measurements

- Trend graph
- Data table

(to be included)

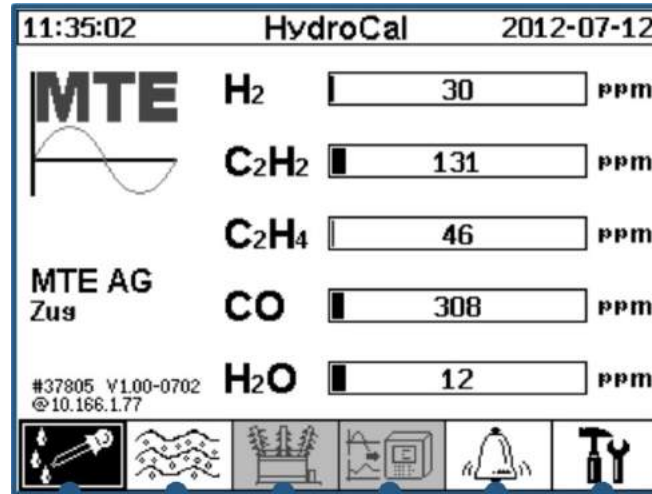

4 Additional sensor measurements

- Trend graph
- Data table

(to be included)

5 Alert overview

- Alert acknowledgement
- Alert table

6 Device setup

- Alert level setting
- Communication setting
- Transformer setting
- In- and output setting

Extraction status

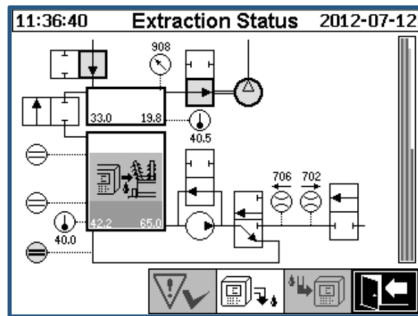

Shows the status of the extraction process and information of safety functions.

Gas-in-oil overview

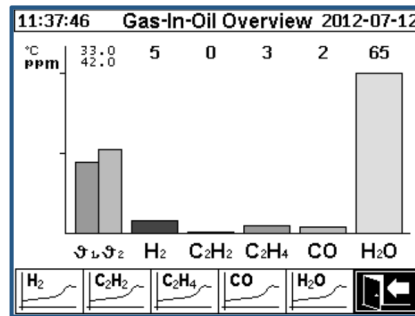

Individual chart diagram for Hydrogen (H₂), Carbon Monoxide (CO), Acetylene (C₂H₂), Ethylene (C₂H₄), Moisture in oil (H₂O) and temperatures.

Alert overview

Selection of Alert			
#	Name	Date/Time	Status
1	H2-Alert	07-12 11:56	✓
2	CO-Alert	07-12 11:58	▲
3	C2H2-Alert	07-12 11:58	▲
4	C2H4-Alert	07-12 11:58	▲

Display of alarm list. Details of each alarm and individual settings is shown.

HydroSoft PC-Software

Program key features

- Configuration and administration of each individual HYDROCAL unit
- Data and configuration read out of HYDROCAL units
- Processing and presentation of data read out (trend or table)
- Further processing of the processed data (Excel, CSV, clipboard and printing)
- Storage of the processed data and unit configuration
- Automatic data read out and alerting by e-mail

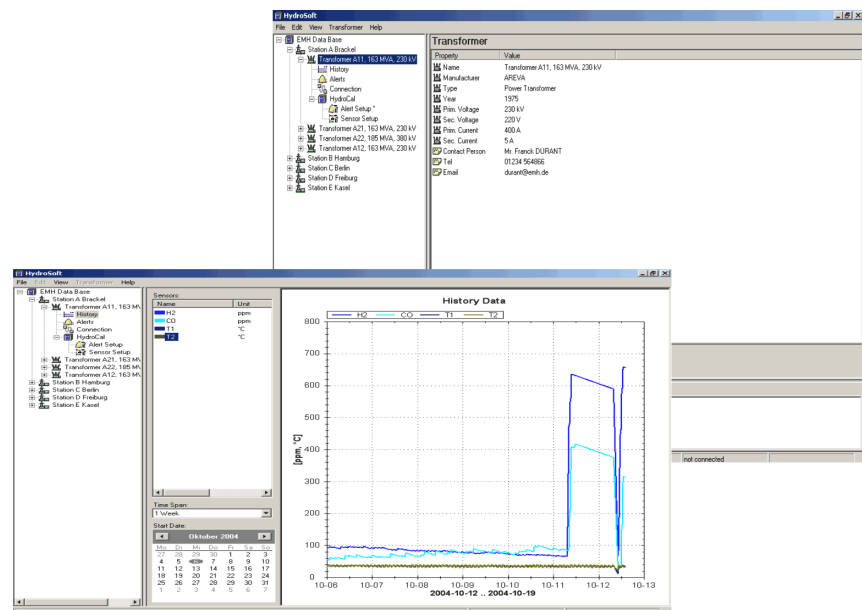

Technical data HYDROCAL 1005 Offshore

General

Optional nominal voltages of auxiliary supply:	120 V -20% +15% AC 50/60 Hz ¹⁾ or 230 V -20% +15% AC 50/60 Hz ¹⁾ or 120 V -20% +15% DC ¹⁾ or 230 V -20% +15% DC ¹⁾ Other nominal voltages on request!
Power consumption:	max. 350 VA
Housing:	Aluminium with painting C5M / stainless steel V4A
Dimensions:	W 263 x H 274 x D 312 mm
Weight:	approx. 16.5 kg
Operation temperature: (ambient)	-55°C ... +55°C (below -10°C display function locked)
Oil temperature: (inside transformer)	-20°C ... +90°C
Storage temperature: (ambient)	-20°C ... +65°C
Oil pressure:	up to 800 kpa (negative pressure allowed)
Connection to valve:	G 1½" DIN ISO 228-1 or 1½" NPT ANSI B 1.20.1

Safety

Isolation protection:	CE certified
Degree of protection:	IEC 61010-1:2002 IP-55

Measurements

Gas / Moisture in oil measurement		Accuracy ^{2) 3)}
Measuring quantity	Range	
Hydrogen H ₂	0 ... 2.000 ppm	± 15 % ± 25 ppm
Carbon Monoxide CO	0 ... 5.000 ppm	± 20 % ± 25 ppm
Acetylene C ₂ H ₂	0 ... 2.000 ppm	± 20 % ± 5 ppm
Ethylene C ₂ H ₄	0 ... 2.000 ppm	± 20 % ± 10 ppm
Moisture in oil H ₂ O	0 ... 100 ppm	± 3 % ± 3 ppm

Operation principle

- Miniaturized gas sample production based on headspace principle (no membrane, negative pressure proofed)
- Patent-pending oil sampling system (EP 1 950 560 A1)
- Near-infrared gas sensor unit for CO, C₂H₂ and C₂H₄
- Micro-electronic gas sensor for H₂
- Thin-film capacitive moisture sensor H₂O
- Temperature sensors (for oil and gas temperature)

Analog and digital outputs

5 x Analog DC outputs		Default concentration (Free assignment)
Type	Range	
1 x Current DC	0/4 ... 20 mADC	Hydrogen H ₂
1 x Current DC	0/4 ... 20 mADC	Acetylene C ₂ H ₂
1 x Current DC	0/4 ... 20 mADC	Ethylene C ₂ H ₄
1 x Current DC	0/4 ... 20 mADC	Carbon Monoxide CO
1 x Current DC	0/4 ... 20 mADC	Moisture in Oil H ₂ O

5 x Digital outputs		Max. Switching capacity (Free assignment)
Type	Control voltage	
5 x Relay ⁴⁾	12 VDC	220 VDC/VAC / 2 A / 60 W

Analog inputs and digital outputs (option)

6 x Analog AC inputs		Accuracy	Remarks
Type	Range		
6 x Current AC or 6 x Voltage AC	0/4 ... 20 mA +20% or 0 ... 80 V +20%	≤ 1.0 %	Configurable by jumpers ⁶⁾

4 x Analog DC inputs		Accuracy	Remarks
Type	Range		
4 x Current DC	0/4 ... 20 mADC	≤ 0.5 %	

5 x Digital outputs		Max. Switching capacity (Free assignment)
Type	Control voltage	
5 x Optocoupler ⁵⁾	5 VDC	U _{CE} : 24 V rated / 35 V max. U _{EC} : 7 V max. I _{CE} : 40 mA max.

Communication

- RS 485 (proprietary or MODBUS[®] RTU/ASCII protocol)
- ETHERNET 10/100 Mbit/s modem copper-wired / RJ 45 or fibre-optical / SC Duplex (proprietary or MODBUS[®] TCP protocol)
- On-board GSM or analog modem for remote access (option)
- On-board DNP3 serial modem (option)

Notes

- 1) 120 V ⇒ 120 V -20% = 96 V_{min} 120 V +15% = 138 V_{max}
230 V ⇒ 230 V -20% = 184 V_{min} 230 V +15% = 264 V_{max}
- 2) Related to temperatures ambient +20°C and oil +55°C
- 3) Accuracy for moisture in oil for mineral oil types
- 4) Relay 1: System alarm / Relay 2 ... 5: Free assignment
- 5) Optocoupler 1 ... 5: Free assignment
- 6) Default jumper configuration: Current

Connections

