



AEROSPACE

- Our Hawk Cargo Hook is designed for aircraft lifting up to 1500kg (3300lb).
- The Hawk has EMC protection and has been selected and approved by Kawasaki Heavy Industries for use on MCH-101 Merlin for the Japanese Maritime Self-Defence Forces.
- The design is of simple construction involving no delicate mechanisms requiring fine adjustment.
- Load release is via electrical solenoid and emergency release cable with separate guarded lever override.
- The Hawk is available with load measurement to enable pilots to know the cargo's weight and monitor the airframe.

Kawasaki Heavy Industries

The Hawk has been selected by Kawasaki for installation on MCH-101 Merlin.

Releases 2.5 Times Rated Load

Capable of releasing 2.5 times rated load mechanically; this extra margin of safety allows the hook to be released in emergency overload situations.

Now Available with Load Measurement

Available with load measurement, which enables the pilot to avoid overload situations.

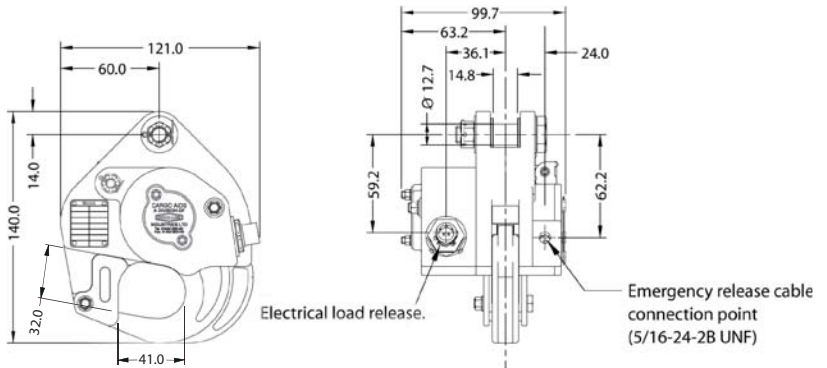

Hook Specification

Part Number:	165CA42
Design Load:	1,500 Kg
Proof Load:	3,750 Kg (x2.5)
Ultimate Load:	6,750 Kg (min)
Mechanical Release Capacity:	3,750 Kg (min)
Release:	Manual Lever & Electrical
Load Indication:	Yes - Load Pin
Force Required for Mechanical Release at 500 - 1500kg:	1.5 - 9.0 Kg
Minimum Release Load:	0 Kg
Unit Weight:	1.5 Kg
Electrical Requirement:	22-28V DC
Electrical Connector:	PC07A-8-2P
MIL Qualified:	WHL (EH101)

HAWK 1500

The Drallim Group

Leading innovators in technology and quality